

AC-DAC-COTO

Digital to Analog Audio Converter



AVProconnect

AC-DAC-COTO

AVProconnect

DISCLAIMERS

The information in this manual has been carefully checked and is believed to be accurate. AVProConnect assumes no responsibility for any infringements of patents or other rights of third parties which may result from its use.

AVProConnect assumes no responsibility for any inaccuracies that may be contained in this document. AVProConnect also makes no commitment to update or to keep current the information contained in this document.

AVProConnect reserves the right to make improvements to this document and/or product at any time and without notice.

COPYRIGHT NOTICE

No part of this document may be reproduced, transmitted, transcribed, stored in a retrieval system, or any of its part translated into any language or computer file, in any form or by any means—electronic, mechanical, magnetic, optical, chemical, manual, or otherwise—without express written permission and consent from AVProConnect.

© Copyright 2018 by AVProConnect. All Rights Reserved.

TRADEMARK ACKNOWLEDGMENTS

All products or service names mentioned in this document may be trademarks of the companies with which they are associated.

SAFETY PRECAUTIONS

Please read all instructions before attempting to unpack, install or operate this equipment and before connecting the power supply.

Please keep the following in mind as you unpack and install this equipment:

- Always follow basic safety precautions to reduce the risk of fire, electrical shock and injury to persons.
- To prevent fire or shock hazard, do not expose the unit to rain, moisture or install this product near water.
- Never spill liquid of any kind on or into this product.
- Never push an object of any kind into this product through any openings or empty slots in the unit, as you may damage parts inside the unit.
- Do not attach the power supply cabling to buildingsurfaces.
- Use only the supplied power supply unit (PSU). Do not use the PSU if it is damaged.
- Do not allow anything to rest on the power cabling or allow any weight to be placed upon it or any person walk on it.
- To protect the unit from overheating, do not block any vents or openings in the unit housing that provide ventilation and allow for sufficient space for air to circulate around the unit.

REVISION HISTORY

VERSION NO.	DATE (DD/MM/YY)	SUMMARY OF CHANGE
VS1	03/14/18	First release

CONTENTS

1. Introduction	1
2. Applications	1
3. Package Contents	1
4. System Requirements	1
5. Features	1
6. Operation Controls and Functions	2
6.1 Top Panel	2
6.2 Front Panel.....	2
6.3 Rear Panel	3
6.4 Left Panel.....	3
7. Connection Diagram	4
8. Specifications	5
9. Acronyms.....	6

1. INTRODUCTION

The Digital to Analog Audio Converter is an easy to use product that converts Coaxial or Optical audio signals into analog Stereo (L/R) audio. It can be easily switched between either Coaxial or Optical inputs. With its compact, elegant design and simple LED input status make it easier for users to connect up and use instantly.

2. APPLICATIONS

- HDTV digital output conversion
- 24-bit DAC conversion

3. PACKAGE CONTENTS

- 1×Digital to Analog Audio Converter
- 1×5V/1.2A DC Power Adaptor
- 1×Operation Manual

4. SYSTEM REQUIREMENTS

Source equipment such as a DVD/Blu-ray player or an HDTV and output to active speakers or amplifier with connection cables.

5. FEATURES

- Supports digital audio input (Coaxial/Optical) and stereo analog audio output (L/R)
- Integrated digital interpolator filter and Digital to Analog Converter (DAC)
- Supports uncompressed digital stereo audio input
- Supports S/PDIF audio at 192kHz/24-bit data for conversion to left and right analog channels
- Compact size and easy to install

6. OPERATION CONTROLS AND FUNCTIONS

6.1 Top Panel

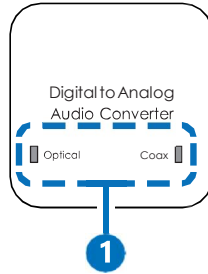

- 1 **Optical & Coax LEDs:** These LED lights will illuminate according to which input is currently selected.

6.2 Front Panel

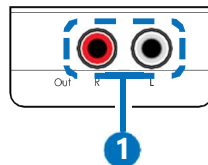

- 1 **L/R Out:** Analog stereo output. Connect to the input of your audio device or display.

6.3 Rear Panel

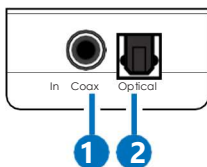

- 1 Coax In:** Connect to the Coaxial digital audio source, such as a DVD player or CD player.
- 2 Optical In:** Connect to the Optical audio source, such as a Blu-ray player or games console.

6.4 Left Panel

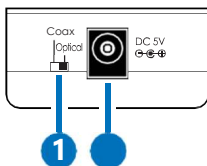

- 1 Coax/Optical Switch:** Select which digital audio input is active and will be converted to analog stereo (L/R) audio.
- 2 DC 5V:** Connect the 5V DC power supply to the unit and plug the adaptor into an AC wall outlet.

7. CONNECTION DIAGRAM

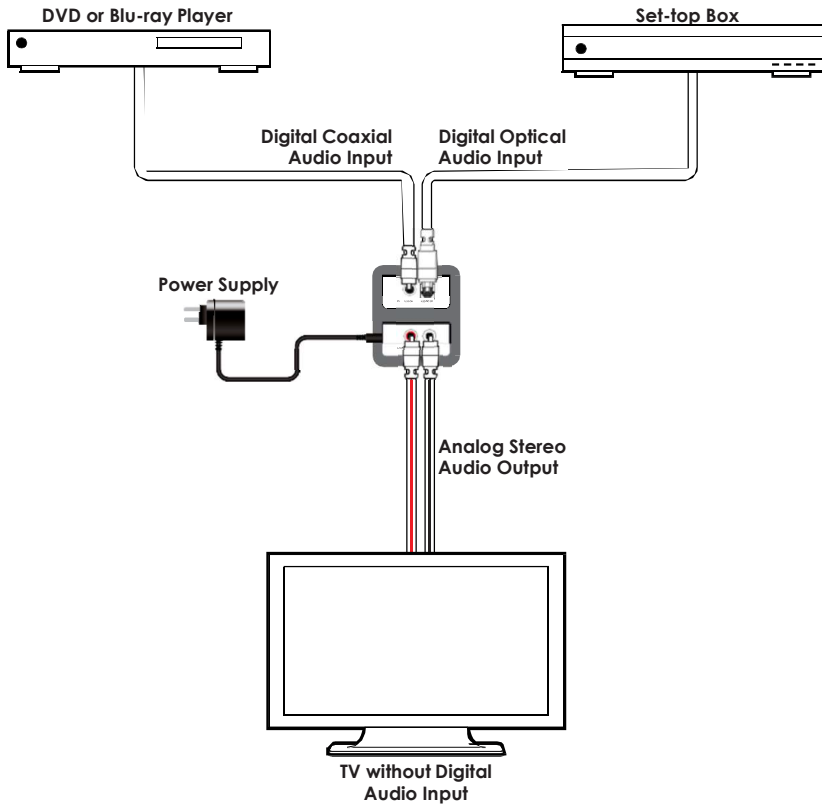

8. SPECIFICATIONS

Input Ports	1×TOSLINK (S/PDIF Audio) 1×RCA (S/PDIF Audio)
Output Ports	2×RCA (Stereo Audio)
Input Audio Format	LPCM 2.0
Output Audio Format	Analog 2.0
Input Sampling Rates	32kHz, 44.1kHz, 48kHz, 88.2kHz, 96kHz, 176.4kHz & 192kHz
Output Level	2Vrms
Output Impedance	600Ω
Power Supply	5V/1.2A DC (US/EU standards, CE/FCC/UL certified)
ESD Protection	Human Body Model: ±12kV (Air Discharge) ±8kV (Contact Discharge)
Dimensions	46mm×22.5mm×45.5mm (W×H×D) [Case Only] 56mm×22.5mm×46mm (W×H×D) [All Inclusive]
Weight	30g
Chassis Material	Plastic
Silkscreen Color	White
Operating Temperature	0°C - 40°C/32°F - 104°F
Storage Temperature	-20°C - 60°C/-4°F - 140°F
Relative Humidity	20 - 90% RH (Non-condensing)
Power Consumption	0.74W

9. ACRONYMS

ACRONYM	COMPLETE TERM
DAC	Digital to Analog Conversion
LPCM	Linear Pulse-Code Modulation
S/PDIF	Sony/Philips Digital Interface Format



THANK YOU FOR CHOOSING AVPROCONNECT!
PLEASE CONTACT US WITH ANY QUESTIONS. WE
ARE HAPPY TO BE OF SERVICE!

AVProconnect



AVPROCONNECT
3518 N CASCO AVENUE ~ SIOUX FALLS, SD
57104
1-877-886-5112 ~ 605-274-6055
SUPPORT@AVPROCONNECT.COM